

# INSTRUCTION BOOK

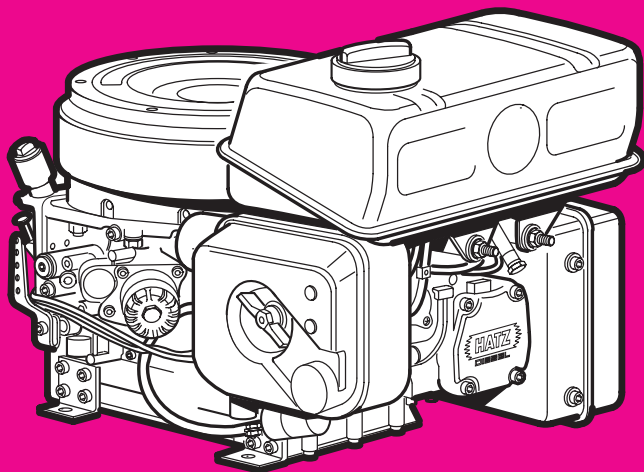

INCLUDES SUPPLEMENTAL INFORMATION TO THE  
OWNER'S MANUAL FOR 2005 AND LATER EPA CERTIFIED  
NONROAD COMPRESSION-IGNITION ENGINES

INCLUDES SUPPLEMENTAL INFORMATION TO THE  
OWNER'S MANUAL FOR 2005 AND LATER CALIFORNIA  
CERTIFIED OFF-ROAD COMPRESSION-IGNITION ENGINES



1D 90 V  
1D 90 W

433 21672-USA-EPA II-CARB  
01.05-0.02  
Printed in Germany

## A new HATZ diesel engine is ready to work for you

This engine is intended only for the purpose determined and tested by the manufacturer of the equipment in which it is installed. Using it in any other manner contravenes the intended purpose. For danger and damage due to this, Motorenfabrik HATZ assumes no liability. The risk is with the user only. Use of this engine in the intended manner presupposes compliance with the maintenance and repair instructions laid down for it. Noncompliance leads to engine breakdown.

Please study this Instruction Book before you start the engine for the first time: it will help you to avoid accidents, to operate the engine correctly, to perform maintenance work and to keep the engine operating at full efficiency for a very long time.

Please follow all maintenance references carefully including the schedule for 2005 and later EPA certified nonroad compression-ignition engines and for 2005 and later CARB certified off-road engines to prevent our environment.

Please pass this Instruction Manual on to the next user or to the following engine owner.



---

Throughout the world, a network of HATZ service stations is at your disposal for advice, spare parts supply and maintenance or repair work.

Please refer to the enclosed list for the address of your nearest HATZ service point.



### Original - Ersatzteile

Original-spare parts

Pièces de rechange d'origine

Repuestos originales

---

Please use only genuine HATZ spare parts. Only these parts guarantee a perfect dimensional stability and quality. Their order numbers are shown in the enclosed Parts List. Please note the complete spare part kits in Table M00 of the list.

In the interests of technical progress we reserve the right to introduce modifications.

**MOTORENFABRIK HATZ GMBH & CO KG**

# Contents

	Page		Page
<b>1. Important notes on safe operation of the engine</b>	3	<b>5.3. Maintenance every 250 hours of operation</b>	19
<b>2. Description of the engine</b>	5	5.3.1. Changing engine oil, renewing oil filter	19
<b>3. General information</b>	6	5.3.2. Checking and adjusting valve clearances	20
3.1. Technical data	6	5.3.3. Clean the cooling air system	21
3.2. Transport	7	5.3.4. Checking threaded connections	21
3.3. Instructions for installation	7	5.3.5. Cleaning mesh insert in exhaust silencer	21
3.4. Load on engine	7		
3.5. EPA/CARB-type plates	8	<b>5.4. Maintenance every 500 hours of operation</b>	22
<b>4. Operation</b>	9	5.4.1. Renewing fuel filter	22
4.1. Before initial start-up	9	5.4.2. Dry-type air cleaner maintenance	22
4.1.1. Engine oil	9	<b>6. Malfunctions – Causes – Remedies</b>	24
4.1.2. Fuel	9	<b>7. Work on the electrical system</b>	27
4.1.3. Mechanical oil pressure monitor	10	<b>8. Protective treatment</b>	27
4.2. Starting the engine	11	<b>SUPPLEMENTAL INFORMATION TO THE OWNER'S MANUAL FOR 2005 AND LATER EPA CERTIFIED</b>	29
4.2.1. Preparations for starting	11	<b>SUPPLEMENTAL INFORMATION TO THE OWNER'S MANUAL FOR 2005 AND LATER CALIFORNIA REGULATIONS FOR OFF-ROAD ENGINES</b>	37
4.2.2. Electric starter	12		
4.3. Stopping the engine	14		
<b>5. Maintenance</b>	15		
5.1. Maintenance summary	15		
5.2. Maintenance every 8 – 15 hours of operation	17		
5.2.1. Check engine oil level	17		
5.2.2. Check air intake point	17		
5.2.3. Air cleaner blockage indicator	17		
5.2.4. Checking cooling air zone	17		
5.2.5. Checking the water trap	18		



This symbol identifies important safety precautions.

Please comply with these most carefully in order to avoid any risk of injury to persons or damage to materials.

General legal requirements and safety regulations issued by the competent authorities or industrial accident insurers must also be complied with.

## 1. Important notes on safe operation of the engine



HATZ diesel engines are economical, strongly built and long-lasting. They are therefore frequently chosen for commercially and industrially operated equipment and machinery.

Since the engine forms part of the finished equipment or machine, its manufacturer will take all the applicable safety regulations into account.

Nevertheless, we give below certain additional comments on operating safety, and would recommend you to note them carefully.

Depending on the manner in which the engine is installed and its intended application, the equipment manufacturer or operator may have to attach additional safety devices and prohibit potentially hazardous aspects of operation, for example:

- Parts of the exhaust system as well as the surface of the engine are of course hot during operation of the engine, but also when it is still cooling down after use, and must not be touched.
- Faulty wiring or incorrect operation of electrical equipment may lead to sparks forming, and must be avoided as a potential fire hazard.
- Rotating parts must be shielded against accidental contact when the engine is installed in other equipment or machinery.  
Guards are available from HATZ to protect belt drives, cooling fans and generators.
- Before attempting to start the engine it is essential to have studied the starting information in the Instruction Book.
- Mechanical starting devices must not be used by children or persons of insufficient physical strength.
- Before starting the engine, ensure that all the specified protective guards are in place.
- The engine must only be operated, serviced or repaired by persons who have received the appropriate training.
- Keep the starting key out of reach of unauthorized persons.
- Never run the engine in closed or badly ventilated rooms.  
Do not breath in emissions - danger of poisoning!
- Also fuel and lubricants could contain poisonous components.  
Please follow the instructions of the mineral oil producer.

## Important notes on safe operation of the engine



- Stop the engine before performing any maintenance, cleaning- and repair work.
- Stop the engine before refuelling.  
Never add fuel near a naked flame or a source of sparks.  
Don't smoke. Don't spill fuel.
- Keep explosive materials as well as flammable materials away from the engine because the exhaust gets very hot during operation.
- Wear close-fitting clothing when working on a running engine.  
Please don't wear necklaces, bracelets or any other things which you could get caught with.
- Please pay attention to all advice- and warning stickers placed on the engine and keep them in legible condition. Contact your next Hatz Servicestation, if a sticker comes off or is illegible and ask for a new one.
- Note that any unauthorized modification to the engine absolves its manufacturer from liability for the consequences.

Regular servicing in accordance with the details provided in this Instruction Book is essential to keep the operating reliably and to ensure the exhaust quality of the engine.

In case of doubt, always consult your nearest HATZ service station before starting the engine.

## 2. Description of engine

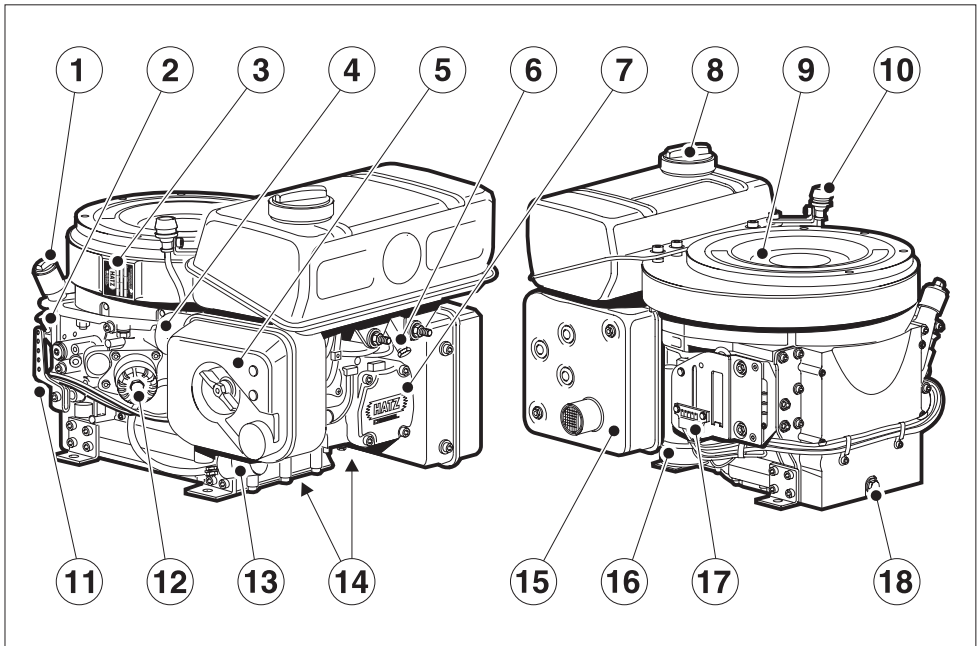

1

- |                         |                                       |
|-------------------------|---------------------------------------|
| 1 Oil filler pipe       | 10 Air cleaner maintenance indicator  |
| 2 Dipstick              | 11 Speed control lever                |
| 3 Type plate            | 12 Oil filter (optional extra)        |
| 4 Combustion air intake | 13 Fuel filter                        |
| 5 Dry-type air cleaner  | 14 Cooling air outlet                 |
| 6 Tank drain plug       | 15 Silencer (muffler)                 |
| 7 Cylinder head cover   | 16 Starter motor                      |
| 8 Tank filler cap       | 17 Central plug for electrical system |
| 9 Cooling air inlet     | 18 Oil drain plug                     |

### 3. General information

#### 3.1. Technical data

Type		1D90.
Engine models		V / W
Mode of operation		air-cooled four-stroke diesel engine
Combustion method		Direct-fuel injection
Number of cylinders		1
Bore / stroke	mm	104 / 85
Displacement	cm <sup>3</sup>	722
Engine oil content without filter with filter	approx. L approx. L	1.5 <sup>1)</sup> 1.6 <sup>1)</sup>
Volume of oil between „max“ and „min“ marks	approx. L	0.7 <sup>1)</sup>
Consumption of lubrication oil after running-in period		approx. 1 % of fuel consumption at full load
Engine oil pressure Oil temperature 100 ± 20 °C		min. 0.6 bar at 850 r.p.m.
Direction of rotation looking at the flywheel		counterclockwise
Valve clearances at 10 - 30 °C Inlet Exhaust	mm mm	0.30 0.30
Max. angle from vertical in any direction (continuous operation)	max.	25° <sup>2)</sup>
Weight (incl. fuel tank, air-cleaner, exhaust silencer and electric starter) Engine models V Engine models W	approx. kg approx. kg	96 98

Model **V**: normal system of balancing, counterclockwise rotation

**W**: add. system of balancing, counterclockwise rotation

<sup>1)</sup> These data are approx.-values. The **max.** mark on oil dipstick counts, fig. 6.

<sup>2)</sup> Exceeding these limits causes engine breakdown.

### 3.2. Transport

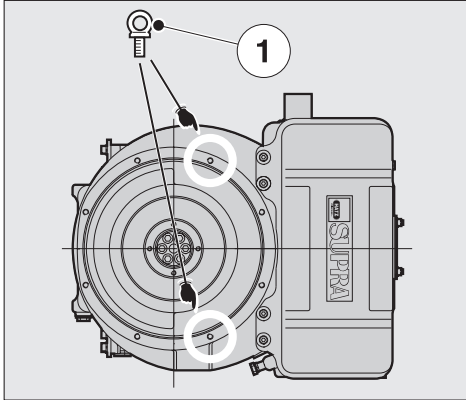

2



**Location for suspension lugs „1“, please see picture 2.**

**Suspension lugs serve for safe engine transport incl. add. equipment. They are not suitable and allowed for lifting complete machines.**

### 3.3. Instructions for installation

The „Manual for Selection and Installation of Engines“ contains all the information you need if your engine has not yet been installed on or in the equipment it is intended to drive, or set up in its correct operating position. You can obtain a copy of this manual from your nearest HATZ service station.

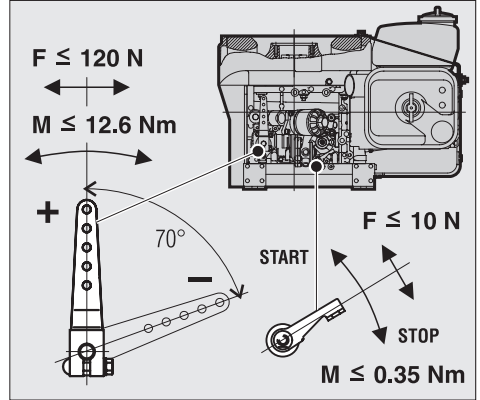

3



**The permitted loads and elements on the speed adjusting lever and the stop lever should be observed as an excess can lead to damage to the contacts and inner governor parts.**

### 3.4. Load on engine









See supplemental information for EPA certified engines, Page 29; resp. supplemental information for California regulations for off road engines, Page 37.











### 3.5. EPA/CARB-type plates

The layout of the EPA/CARB-type plate depends on the engine application and is placed on the crankcase (chapt. 2).

It includes the following engine information (Figures 4a and 4b):

 <b>IMPORTANT ENGINE INFORMATION</b> 		
MOTORENFABRIK HATZ  KG · D-94099 RUHSTORF		
ENG.FAM.		
①		
TYPE / SPEC./ FDT		
②		
SERIAL NO.	CM <sup>3</sup> / PV	
③	⑥	
MIN <sup>-1</sup>	NH / kW	BUILD DATE
④	⑦	⑤
VARIABLE SPEED		Made in Germany
This engine conforms to MY <input type="checkbox"/> U.S. EPA regulations large nonroad compression-ignition engines and MY <input type="checkbox"/> California regulation for off-road compression-ignition engines.		
Refer to Owner's manual for maintenance specifications and adjustments.		
		

4a

 <b>IMPORTANT ENGINE INFORMATION</b> 		
MOTORENFABRIK HATZ  KG · D-94099 RUHSTORF		
ENG.FAM.		
①		
TYPE / SPEC./ FDT		
②		
SERIAL NO.	CM <sup>3</sup> / PV	
③	⑥	
MIN <sup>-1</sup>	NH / kW	BUILD DATE
④	⑦	⑤
CONSTANT-SPEED ONLY		Made in Germany
⑧ This engine conforms to MY <input type="checkbox"/> U.S. EPA regulations large nonroad compression-ignition engines and MY <input type="checkbox"/> California regulation for off-road compression-ignition engines.		
Refer to Owner's manual for maintenance specifications and adjustments.		
		

4b

- ① EPA/CARB-Engine Family Number
- ② engine type/spec. (only for special equipment) /Fuel Delivery Timing
- ③ engine number
- ④ max. engine rated speed
- ⑤ build date
- ⑥ displacement
- ⑦ rated power
- ⑧ "constant speed only" (if requested)

Every engine is equipped with an additional loose engine type plate. If the original type plate on the engine is not readily visible after the engine is installed in the equipment then the second loose type plate must be attached on the equipment in such a manner that it is readily visible to an average person.

For any offer as well as spare parts orders it is necessary to mention the following data (also see spare parts list, page 1):

- ② engine type/spec.  
(only for special equipment)
- ③ engine number
- ④ max. engine rated speed

## 4. Operation

### 4.1. Before initial start-up

Engines are normally delivered without fuel and oil.

#### 4.1.1. Engine oil

##### Oil quality

Qualified are all trademark oils which fulfil at least one of the following specifications:

**ACEA – B2 / E2** or more significant

**API – CD / CE / CF / CF-4 / CG-4** or more significant.

If engine oil of a poorer quality is used, reduce oil change intervals to 150 hours of operation.

##### Oil viscosity:

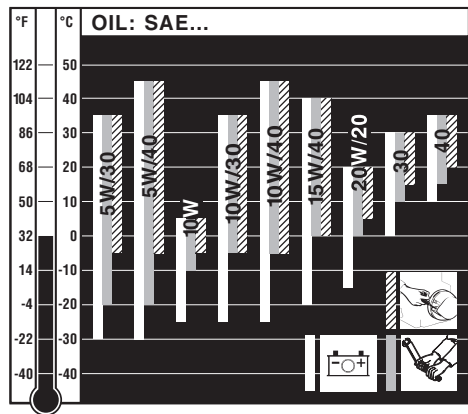

5

Choose a viscosity according to the ambient temperatures where the engine is to be started from cold.

The engine must be in a horizontal position before adding oil or checking the oil level.

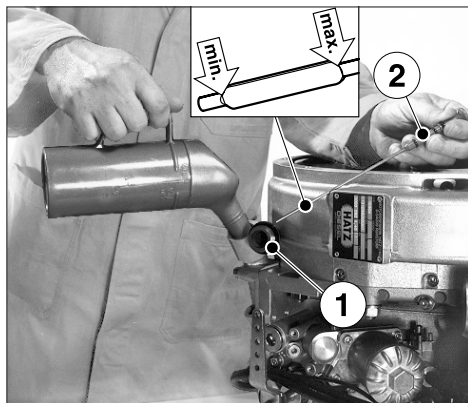

6

- Remove oil fill screw „1“ and dipstick „2“.
- Add engine oil up to the **max.** mark on the dipstick.  
Lubricating oil capacity: see Chapter 3.1.
- Tighten oil fill screw by hand.

#### 4.1.2. Fuel



**Only refuel when engine is stopped. Never refuel close to open flames or flammable sparks, don't smoke. Use only pure fuel and clean replenishing cups. Don't spill the fuel.**

All diesel fuels sold as fuel and complying with the following minimum specification can be used:

**EN 590** or  
**BS 2869 A1 / A2** or  
**ASTM D 975 - 1D / 2D**



7

- Add diesel fuel to the fuel tank until it is at least half full.  
The fuel system is bled automatically if the fuel tank is attached to the engine or located higher than the injection pump.

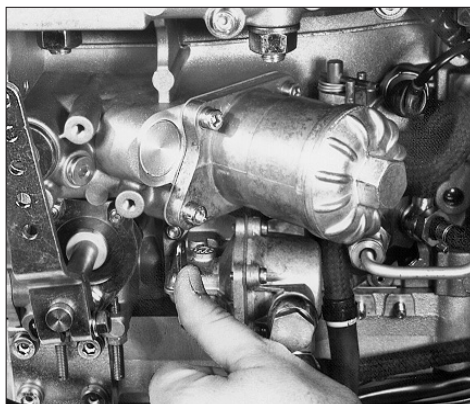

8

- If the fuel tank is not mounted on top of the engine, or is at a lower level, operate the lever on the fuel feed pump until fuel is heard to flow back to the tank through the return line.

At temperatures below 0 °C, winter-grade fuel should be used or paraffin added to the fuel well in advance.

Lowest ambient temperature when starting, in °C	Paraffin content for:	
	Summer fuel	Winter fuel
0 up to -10	20 %	-
-10 up to -15	30 %	-
-15 up to -20	50 %	20 %
-20 up to -30	-	50 %

#### 4.1.3. Mechanical oil pressure monitor (optional extra)

The mechanical oil pressure monitor should be activated:

- when first filling, or after running the fuel tank dry.
- if engine shut down automatically because lubricating oil supply was inadequate.

- Add fuel, chap. 4.1.2.
- Check engine oil level, chap. 5.2.1.

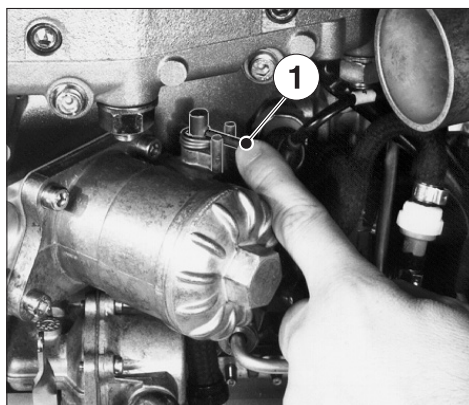

9

- To activate the monitor, press lever „1“ for approx. 5 seconds.

- If the engine has a fuel feed pump, operate its lever for several strokes at the same time (Fig. 8).

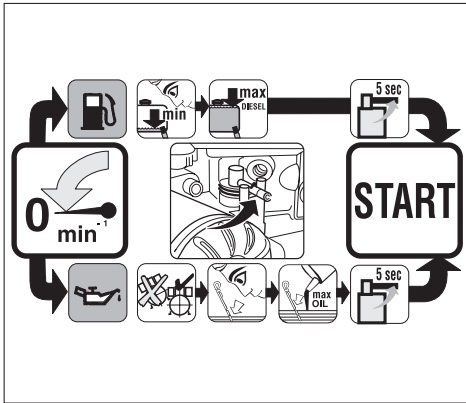

10

Instructions to activate the mechanical oil pressure control are mentioned on the sticker placed on the engine.

**IMPORTANT !**

Even with mechanical oil pressure monitoring the oil level must be checked every 8 – 15 operating hours.

**4.2. Starting the engine**



Do not run the engine in closed or badly ventilated rooms – danger of poisoning! Before the engine is started, always make sure that nobody is in the danger area (moving parts on engine or machinery) and that all safety guards are in place.

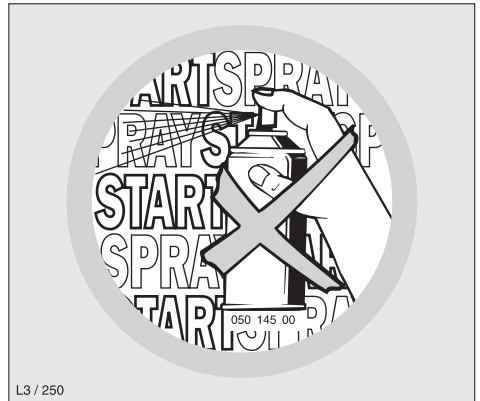

11

Never use any spray starting aids.

**4.2.1. Preparations for starting**

- If possible, disengage the engine from any driven equipment.  
The auxiliary equipment should always be placed in neutral.

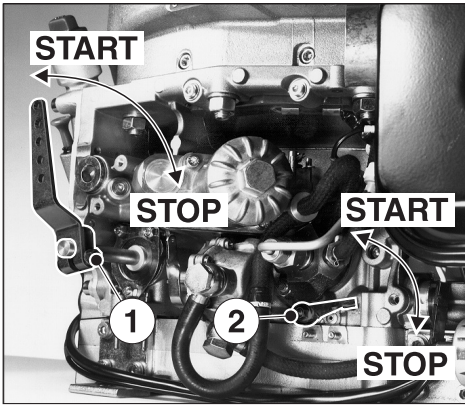

12

- Set speed control lever „1“ to a position between 1/2 START and max. START, according to requirements.  
Selecting a lower engine speed will reduce smoke when starting.
- Make sure that stop lever „2“ - if fitted - is in the operating „START“ position.

#### 4.2.2. Electric starter

For preparations to start, see Chapter 4.2.1.

##### Starting procedure

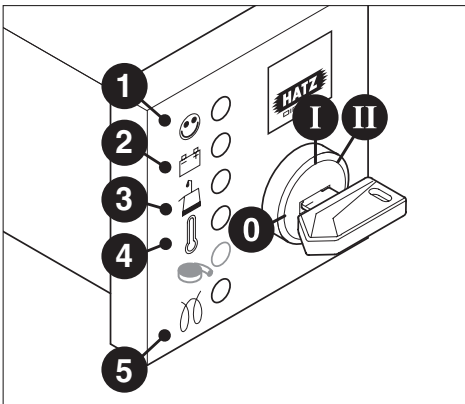

13

- Insert start key and turn to **position I**

- Battery charge telltale „2“ and oil pressure warning „3“ must light up (Fig. 13).
- Turn start key to **position II** (Fig. 13).
- As soon as the engine runs, release the start key. It must return to **position I** by itself and remain in this position during operation.  
The battery charge telltale and oil pressure warning must go out immediately after starting. Indicator light „1“ is on when the engine is in operation.
- If anything seems to be incorrect, stop the engine immediately and trace and rectify the fault (chapt. 6).
- The engine temperature display „4“ (additional equipment) lights up if the temperature at the cylinder head becomes too high.  
**Switch off the engine and trace and eliminate the cause of the problem, chapter 6.**
- Always turn the start key back to **position 0** before re-starting the engine. The repeat lock in the ignition lock prevents the starter motor from engaging and possibly being damaged while the engine is still running.



**Never operate the electric starter when the engine is running or coasting to a standstill. There is a risk of broken starter pinion or ring gear teeth.**

##### Important!

If a starter protection module is installed, the start key has to be returned to **position 0** for at least 8 seconds after the engine has failed to start or after switching it off before a further attempt can be made to start the engine.

##### Preheating device with automatic heating timer (additional equipment)

The preheating light „5“ lights up additionally at temperatures below 0° Celsius (Fig. 13).

- After the light has gone out, start the engine without delay.

## **Automatic shut-down function**

(additional equipment)

This is characterized by a brief flashing of all pilot lamps once the starter key has been turned to **position I** (Fig. 13).

### **Important!**

If the engine cuts out immediately after starting or switches off by itself during operation, a monitoring element in the automatic shutdown system has tripped. The corresponding indicator light (Fig. 13, positions 2 - 4) will come on. After the engine has stopped, the display continues to glow for about 12 seconds.

The electrical device then switches itself off automatically.

The display lights up again after the start key has been turned back to **position 0** and then to **position I** again.

**Trace and eliminate the cause of the operating fault before trying to restart the engine (see chapter 6).**

The display light goes out when the engine is next started.

**Even with automatic shutdown monitoring the oil level must be checked every 8–15 operating hours** (chapter 5.2.1.).

### 4.3. Stopping the engine



During breaks in work or at the conclusion of the working period, keep the starting key in a safe place, out of reach of unauthorized persons.

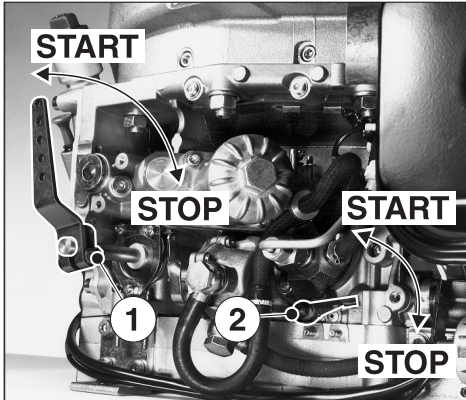

14

- Move speed control lever „1“ back to the STOP position.
- On engines with the lower engine speeds not accessible, move speed control lever „1“ back, then move stop lever „2“ (optional extra) in the STOP direction. Hold it there until the engine has stopped.
- Release the stop lever „2“ when the engine has stopped, making sure that the lever returns to its normal operating position.

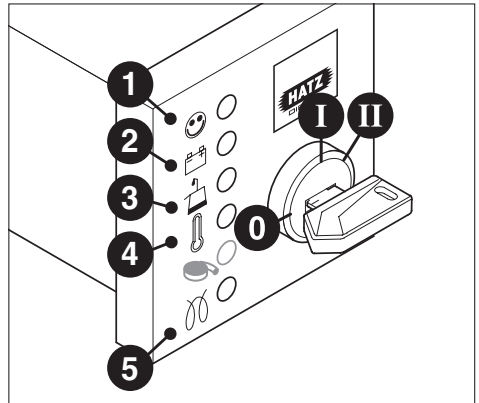

15

The charge „2“ and oil pressure telltales „3“ come on.

- Turn the key to the **0 position** and pull it out. The telltale lights must then go out.

#### Note:

Engines with an automatic shut-down function (chapter 4.2.2.), can also be switched off by turning the start key back to **position 0**.

## 5. Maintenance



The engine must be stopped before any maintenance work is attempted.

Comply with legal requirements when handling and disposing of old oil, filters and cleaning materials.



Keep the engine's starting key out of reach of unauthorized persons.

Disconnect the negative battery terminal.

At the end of the maintenance work, check that all tools have been removed from the engine and all safety guards, covers etc. replaced in their correct positions.

Before starting the engine, make sure that nobody is in the danger area (engine or driven machinery).

### 5.1. Maintenance summary

	Maintenace intervals	Maintenance work required	Chap.
	Every 8 – 15 operating hours or before daily starting.	Check oil level.	5.2.1.
		Check area round combustion air input.	5.2.2.
		Check the air cleaner maintenance indicator.	5.2.3.
		Check the cooling air zone.	5.2.4.
		Check the water trap.	5.2.5.
	Every 250 operating hours	Replace engine oil and oil filter.	5.3.1.
		Check and adjust tappet clearance.	5.3.2.
		Clean cooling air system.	5.3.3.
		Examine screw connections.	5.3.4.
		Cleaning mesh insert in exhaust silencer	5.3.5.
	Every 500 operating-hours	Replace fuel filter.	5.4.1.
		Maintenance of dry-air filter.	5.4.2.



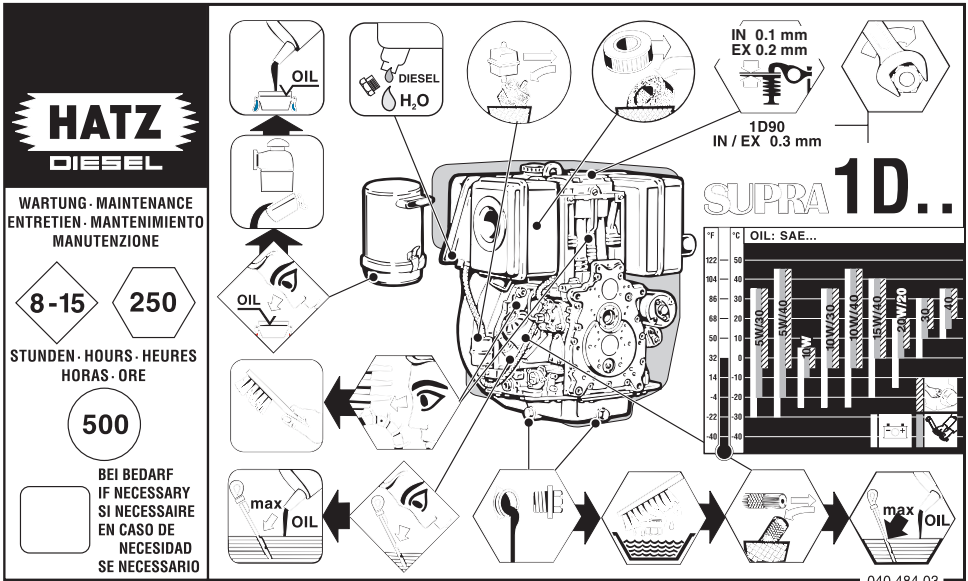

16

The above maintenance chart is supplied with every engine. This label should be affixed to the engine or equipment in an easily visible position. The maintenance chart governs the maintenance intervals.

For **new** or **reconditioned** engines, the following must always be carried out after **first 25 operating hours**:

- Replace engine oil and oil filter, chap. 5.3.1.
- Check tappet clearance, and adjust if necessary, chap. 5.3.2.
- Examine screw connections, chap. 5.3.4.  
**Do not tighten the cylinder head fastening.**

**For short operating periods:** replace engine oil and oil filter **after 12 months at the latest**, regardless of the number of operating hours.

## 5.2. Maintenance every 8 – 15 hours of operation

### 5.2.1. Check engine oil level

When checking the oil level, the engine should be standing level, and must not be running.

- Remove any dirt in the dipstick area.

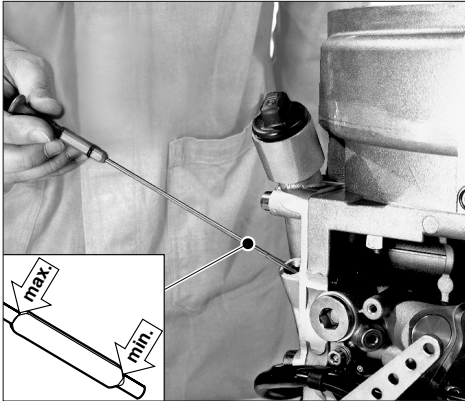

17

- Check oil level at the dipstick; top up if necessary as far as the „max“ mark (see Chapter 4.1.1.).

### 5.2.2. Check air intake point

Severe contamination is a sign that there are large amounts of dust in the atmosphere and the air cleaner maintenance intervals should be reduced.

- Depending on the air intake pattern, check for severe blockage; clean if necessary (see Chapter 2).

### 5.2.3. Air cleaner blockage indicator (optional extra)

- Run the engine at full speed shortly.



18

If the rubber bellows is pulled in and obscures the green zone „1“, maintenance work is due on the air cleaner, Chapt. 5.4.2.

In dusty operating conditions, check the rubber bellows several times a day.

### 5.2.4. Checking cooling air zone

Severe contamination is a sign that there are large amounts of dust in the atmosphere and that maintenance intervals should be reduced.

- Check the air inlet and outlet zones for blockage by coarse material such as leaves, large amounts of dust etc., and clean if necessary (see chapters 2 and 5.3.3.).

If a temperature warning light „4“ is provided, it will come on if the engine overheats (Fig. 15).

**In this case, stop the engine immediately** (Chapters 4.3. and 5.3.3.).

### 5.2.5. Checking the water trap

The intervals at which you should check the water trap depend entirely on the amount of water in the fuel and the care taken when refuelling. The normal interval is once a week.

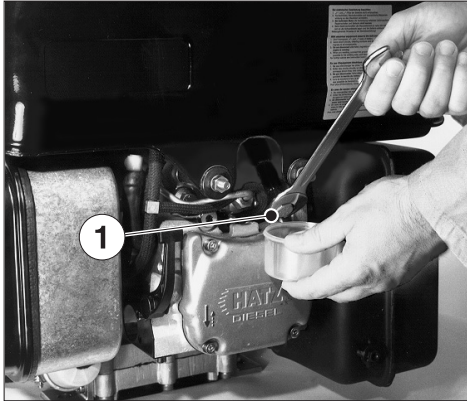

19

- Loosen hexagon screw „1“ with approx. 2-3 rotations.
- Trap the drops which emerge in a transparent vessel. Since water has a greater specific gravity than diesel fuel, the water emerges before the diesel fuel. The two substances separate at a clearly visible line.
- As soon as diesel only emerges at screw „1“, this can be tightened again.

If an external water trap is attached, check its water content every day, when the engine oil level is checked.

The water which has collected is separated at a clearly visible line from the diesel fuel above it.



20

- Open drain plug „1“ and drain the water out into a suitable vessel.

If the drain plug is difficult to reach, an extension hose can be attached to it.

### 5.3. Maintenance every 250 hours of operation

#### 5.3.1. Changing engine oil, renewing oil filter

The engine must be stopped, and should stand on a flat, level surface.

Drain the engine oil only when it is warm.



**Danger of scalding from hot oil.**  
Trap the old oil and dispose of it in accordance with local legislation.

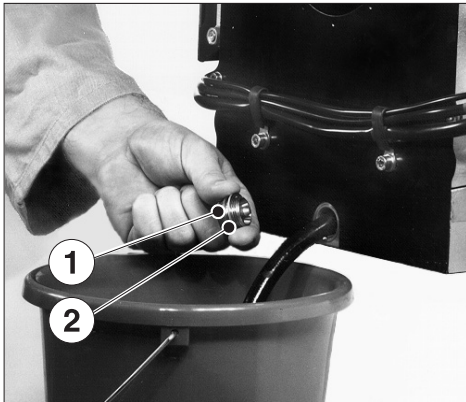

21

- Unscrew the oil drain plug „1“ and allow all the oil to drain out.
- Clean the oil drain plug and attach a new seal „2“. Insert and tighten the plug.

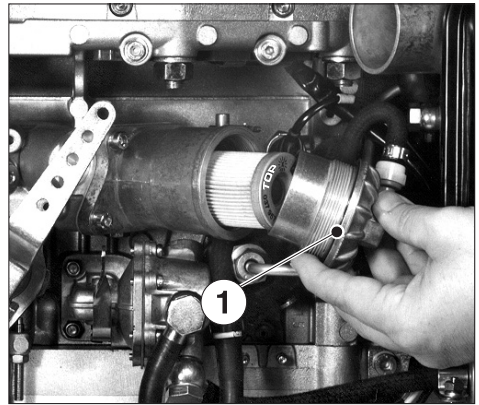

22

- Renew the replaceable lubricating oil filter-element (optional extra). Catch leaking oil!

**Important!**  
Note the „TOP“ mark on the oil filter.



23

- Clean sieve bottom carefully in order not to bend the netting. Wipe out cap screw or blow it out with compressed air.
- Check condition of O-ring „1“ and renew it if necessary (Fig. 22).
- Wet the thread and the O-ring of the drain plug with lubricant „K“ (see spare parts list).

- Add engine oil up to the „max“ mark on the dipstick (see Chapter 4.1.1.).
- Run the engine for a short period, then check the oil level again and top up if necessary.
- Check that there is no leakage past screw plug on the oil filter housing.

### 5.3.2. Checking and adjusting valve clearances

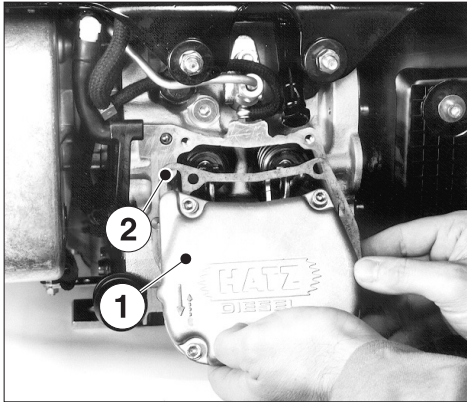

24

- Unscrew cover „1“ and take off together with gasket „2“. Never re-use this gasket.
- Turn the engine over in the normal direction of rotation until compression is felt.

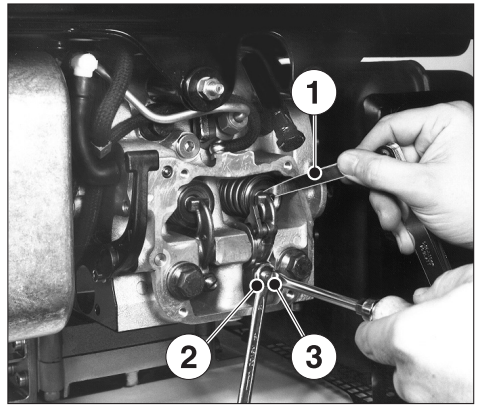

25

- Check valve clearances between rocker and valve stem, using feeler gauge „1“; (see Chapter 3.1.).
- If valve clearance is incorrect, slacken off hex. nut „2“.
- Turn adjusting screw „3“ with a screwdriver until feeler gauge „1“ can just be pulled through between the rocker and the valve stem with slight resistance to its movement after nut „2“ has been retightened.
- Attach the cover at the cylinder head again and tighten down uniformly.
- Run the engine briefly and check that the cover is not leaking.

### 5.3.3. Clean the cooling air system



**Before cleaning, the engine must be stopped and allowed to cool down.**

- Remove parts of air duct.

#### Dry contamination

- Clean all air guide elements and the complete cooling air zones on the cylinder head, cylinder and flywheel blades without making them wet. Blow them dry with compressed air.

#### Moist or oily contamination

- Disconnect the battery. Clean the complete area with a solvent, cold cleaner etc. according to its manufacturer's instructions, then spray down with a powerful water jet. Do not splash electrical device with water jet or pressure jet during engine cleaning.
- Trace the cause of any contamination with oil and have the leak eliminated by a HATZ service station.
- Install the air guide elements previously removed.



**The engine must never be run without the air guide elements in position.**

Immediately after re-assembly, run the engine until warm to prevent residual moisture from causing rust.

### 5.3.4. Checking threaded connections

Check the condition and tightness of all threaded connections, wiring, hose clips and other components attached to the engine and its mountings, provided that these can be reached during maintenance work.

**Do not tighten the cylinder head bolts.**

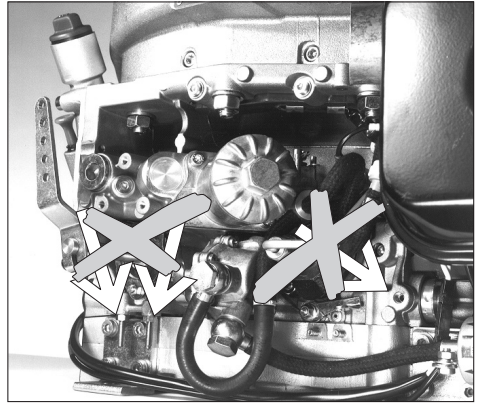

26



**Adjustment screws on speed governor and injection system are painted with safety lacquer. Do not tighten or adjust them.**

### 5.3.5. Cleaning mesh insert in exhaust silencer (additional equipment)

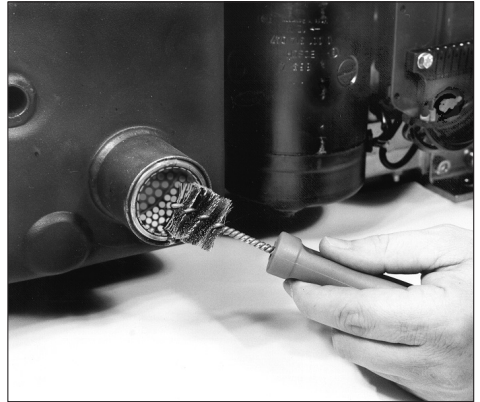

27

- Remove deposits from the mesh insert with a suitable wire brush.

## 5.4. Maintenance every 500 hours of operation

### 5.4.1. Renewing fuel filter

Fuel filter maintenance intervals depend on the purity of the fuel used; reduce them to 250 hours of operation if necessary.



**Do not smoke or bring a naked flame near the fuel system when working on it.**

- Place a suitable vessel under the filter to trap escaping fuel.
- Close the fuel supply line.

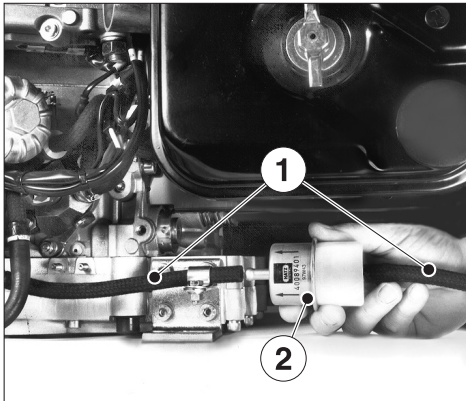

28

- Pull fuel supply line „1“ off fuel filter „2“ at both sides, and insert the new filter.

#### **Important!**

**Keep the entire area clean so that no dirt reaches the fuel. Fuel particles may damage the injection system.**

- Always renew the fuel filter. Note the arrows indicating the correct direction of fuel flow.
- Open the fuel supply line or prime the pump until the fuel flows (see Chapter 4.1.2.).

- Run the engine briefly to check the fuel filter and lines for leaks.

### 5.4.2. Dry-type air cleaner maintenance

It is best to clean the filter cartridge only when the maintenance indicator displays the appropriate signal.

Apart from this, the cartridge should be renewed after 500 hours of operation.

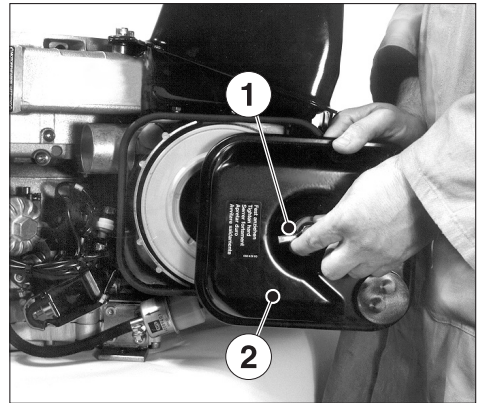

29

- Slacken off wing bolt „1“ and remove it with cover „2“.

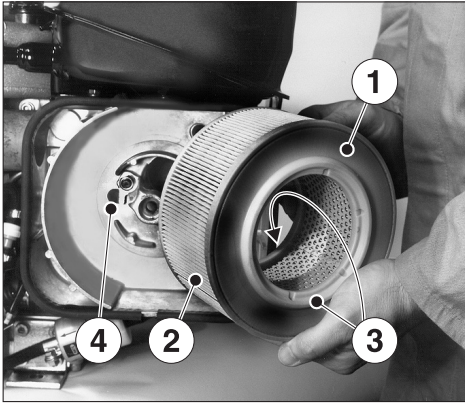

30

- Carefully pull out filter cartridge „1“.
- On the version with air cleaner maintenance indicator, check that valve plate „4“ is clean and in good condition.

## Cleaning the filter cartridge

### Dry contamination

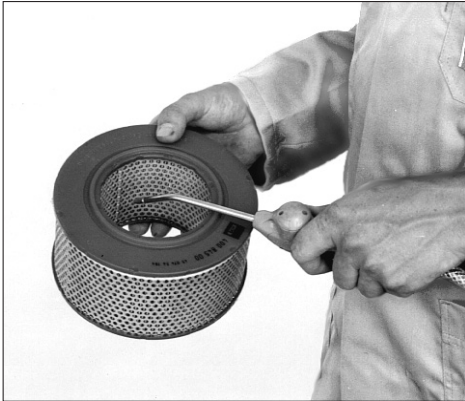

31

- Blow through the filter cartridge from the inside, moving the jet of dry compressed air up and down until no further dust is expelled.
- Warning: air pressure must not exceed 5 bar.**

- Tilt the filter element and hold it against the light (or shine a light through it) to trace any cracks or other damage.

### Important!

**If there is even the slightest damage to paper filter element „2“ or sealing lips „3“, the filter element should not be re-used. (Fig. 30)**

### Wet or oily contamination

- Renew the filter cartridge.
- Re-assemble in the reverse order of work.



## 6. Malfunctions – Causes – Remedies

Malfunction	Possible causes	Remedial action	Chap.
Engine will not start or start is delayed, although it can be turned over with the starter.	Speed control lever is in stop or idle position.	Set lever to „START“-position	4.2.
	Stop lever in stop position.	Add. fuel.	4.1.2. 4.1.3.
	No fuel reaching injection pump.	Check entire fuel supply system carefully. If no fault is found: - supply line to engine - fuel filter - Function of delivery pump must be checked.	5.4.1. 4.1.2.
	Compression too low: - Valve clearances incorrect	Check valve clearances, adjust if necessary. See workshop manual.	5.3.2.
	- Valves worn - Cylinder bore and/or piston ring wear	See workshop manual.	
	Injector not operating correctly.	See workshop manual.	
Also applicable for engines with mechanical oil pressure monitoring.	Oil pressure lost.	Check engine oil level.  Activate mechanical oil pressure monitor.	5.2.1.  4.1.3.
	Lower starting temperature limit exceeded.	Operate preheat system (optional extra).	4.2.2.
At low temperatures.	Machinery not uncoupled.	Disengage engine from machinery or equipment if possible.	
	Defective preheat system (optional extra).	See workshop manual.	

<b>Malfunction</b>	<b>Possible causes</b>	<b>Remedial action</b>	<b>Chap.</b>
At low temperatures.	Fuel separates has inadequate resistance to low temperatures.	Check whether clear (not turbid) fuel emerges at the fuel line detached from the injection pump. If turbid or separated - either warm up the engine or drain the complete fuel supply system. Refuel with winter-grade fuel to which paraffin has been added.	4.1.2.
	Starting speed too low: - Engine oil is too thick	Refill with a different grade of engine oil.	5.3.1.
	- Battery charge is insufficient.	Check the battery; consult a specialist workshop if necessary	7.
Starter does not run or engine is not turned over.	Fault in electrical system: - Battery and/or other wiring is wrongly connected. - Wiring connections loose and/or corroded. - Battery defective and/or flat. - Defective starter motor - Defective relays, monitoring elements etc.	Check electrical system incl. indiv. components or contact a HATZ-service station.	7.
Engine fires but stops again as soon as starter is switched off.	Drive still engaged.	Uncouple engine from driven machinery if possible.	
	Fuel filter blocked.	Renew the fuel filter.	5.4.1.
	Fuel supply interrupted.	Check through the entire fuel supply systematically.	
	Stop signal from monitoring element for automatic shutdown system (optional extra):		
	- oil pressure lost - cylinder head temperature too high.	Check oil level. Clean cooling air system.	5.2.1. 5.3.3.
- alternator has failed.	See workshop manual.		

<b>Malfunction</b>	<b>Possible causes</b>	<b>Remedial action</b>	<b>Chap.</b>
Engine stops by itself during regular operation.	Fuel supply is interrupted: - Tank run dry	Add fuel.	4.1.2. 4.1.3.
	- Fuel filter blocked - Defective feed pump.	Renew fuel filter. Check through entire fuel supply system.	5.4.1.
	Mechanical oil pressure monitor stops the engine due to low oil pressure.	Check engine oil level. Activate mechanical oil pressure monitor.	5.2.1. 4.1.3.
	Mechanical defects.	Contact a HATZ-service station.	
In addition, if automatic electrical engine shutdown is installed.	Stop signal from monitoring element because of: - oil pressure too low. - cylinder head temperature too high.	Check engine for: Engine oil level Cooling air passages blocked or cooling system otherwise affected.	5.2.1. 5.3.3.
	- alternator has failed.	See workshop manual.	
Low engine power, output and speed.	Fuel supply is obstructed: - Tank run dry.	Add fuel.	4.1.2. 4.1.3. 5.4.1.
	- Fuel filter blocked. - Tank venting is inadequate	Renew fuel filter. Ensure that tank is adequately vented.	
	- Leaks at pipe unions.	Check threaded pipe unions for leaks.	
	- Speed control lever does not remain in selected position.	Prevent speed control from moving.	
Low engine power, output and speed, black exhaust smoke.	Air cleaner blocked.	Remove dirt from air cleaner.	5.4.2.
	Incorrect valve clearances. Malfunction at injector.	Adjust valve clearances. See workshop manual.	5.3.2.
Engine runs very hot. Cylinder head overheat, telltale lamp (optional extra) comes on.	Too much oil in engine.	Drain off engine oil down to upper mark on dipstick.	5.3.1.
	Inadequate cooling: - Entire cooling air system contaminated.	Clean cooling air system.	5.3.3.
	- Inadequate sealing at air guide plates.	Check that air guide plates and enclosure elements are all present and make a tight seal.	

## 7. Work on the electrical system



**Batteries generate explosive gases. Keep them away from naked flame and sparks which could cause them to ignite. Do not smoke. Protect the eyes, skin and clothing against battery acid. Pour clear water over acid splashes immediately. In case of emergency call doctor. Do not place any tools on top of the battery.**

**Always disconnect the negative (–) pole of the battery before working on the electric device.**

- The **positive (+)** and **negative (–)** battery terminals must not be accidentally interchanged.
- When **installing the battery**, connect the **positive lead** first, followed by the **negative lead**. Negative pole to earth (ground) on engine block.
- When **removing the battery**, disconnect the **negative lead** first, followed by the **positive lead**.
- In all circumstances, **avoid short circuits** and shorts to earth (ground) at live cables.
- If electrical faults occur, first **check** for good contact at the **cable connections**.
- Replace a failed indicator light without delay.
- Do not take the key out while the engine is running.
- Never **disconnect the battery** while the engine is running. Electric voltage peaks can cause damage to electrical components.
- Do not splash electrical device with water jet or pressure jet during engine cleaning.
- When carrying out **welding work** on the engine or attached equipment, attach the earth (ground) clip as near as possible to the welding point, and disconnect the battery. If an alternator is fitted, separate the plug connector leading to the voltage regulator.

The relevant circuit diagrams are supplied with engines which have an electrical system. Additional copies of circuit diagrams can be obtained on request.

HATZ assumes no liability for electrical systems which was not carried out acc. HATZ circuit diagrams.

## 8. Protective treatment

A new engine can normally be stored for up to 12 months in a dry place.

If atmospheric humidity is high (or if exposed to sea air), protection is sufficient for about 6 months' storage.

If the engine is to be stored for a longer period, or laid up out of use, please consult the nearest **HATZ service point**.



**SUPPLEMENTAL INFORMATION  
TO THE OWNER'S MANUAL FOR 2005 AND LATER  
EPA CERTIFIED  
NONROAD COMPRESSION IGNITION ENGINES.**

**EPA EMISSION CONTROL SUPPLEMENTAL  
WARRANTY STATEMENT.**

## **MAINTENANCE AND WARRANTY.**

### **SUPPLEMENTAL INFORMATION TO THE OWNERS MANUAL FOR 2005 AND LATER EPA CERTIFIED NONROAD COMPRESSION IGNITION ENGINES.**

The following supplemental information is furnished for EPA Nonroad Compression Ignition Engines which are certified according to 40 CFR Part 89.

This information contains the following specific items:

- EPA-related engine parts and engine operating conditions
- Maintenance instructions for EPA-related engine parts
- Emission control system and adjustments
- Warranty statement

### **ENGINE PARTS AND / OR EQUIPMENT RELATED TO EPA EXHAUST EMISSION REGULATIONS.**

Parts which are mandatory for engine operation.

The following parts as manufactured according to HATZ specifications are mandatory for engine operation which meets EPA exhaust emission regulations.

- Fuel injection pump
- Injection nozzle
- Extra fuel device
- Crankcase breather valve assembly
- Air cleaner housing
- Intake manifold
- Exhaust manifold

- Oil filler cap
- Intake and exhaust gaskets at head interfaces

Only parts manufactured by Hatz and which have passed the Hatz Quality Assurance Program are assured of meeting EPA exhaust emission regulations.

### **UNUSUAL OPERATING CONDITIONS.**

The engine must not be operated at a load factor less than 25 % for an extended period as such operation will cause the fuel injector to foul. If such a condition occurs, you should contact the nearest HATZ authorized Service Center for necessary repairs.

The engine is designed and adjusted to operate most efficiently at the following conditions:

- Air temperature of 25° C ( 77° F)
- Atmospheric pressure of 100 kPa (14.5 psi)
- Relative humidity of 30 %

Operation of the engine at conditions other than above will affect performance and exhaust emissions. Normally the equipment manufacturer takes this into account during the design of the machine and your equipment will perform within specifications over a wide range of climatic conditions. However if you must operate your equipment under very unusual climatic conditions, please contact your nearest Hatz distributor for advice.



## **MAINTENANCE SCHEDULE-EPA-RELATED PARTS**

The following minimum intervals are being adopted for adjustment, cleaning, repair, or replacement of following components:

At 1,500 hours, and 1,500-hours intervals thereafter:

- Fuel injector tips (cleaning only)

At 3,000 hours, and 3,000-hours intervals thereafter:

- Fuel injector

The exhaust quality of the engines can be influenced by the execution (the quality of execution) of above described maintenance work.

Therefore, the maintenance work has to be carried out by a qualified workshop. Hatz authorised workshops, for example, are qualified workshops.

Hatz Diesel of America will give you respective addresses, if required.

## **EMISSION CONTROL SYSTEM AND ADJUSTMENTS.**

The emission control system for this engine is EM (Engine Modification). No adjustments are needed or possible.

## **EPA EMISSION CONTROL WARRANTY STATEMENT**

### **YOUR WARRANTY RIGHTS AND OBLIGATIONS.**

Motorenfabrik Hatz GmbH & Co. KG warrants the emission control system on your engine for the periods of time listed below provided there has been no abuse, neglect or improper maintenance of your engine.

Your emission control system includes:

- Fuel injection pump
- Injection nozzle
- Extra fuel device
- Crankcase breather valve assembly
- Air cleaner housing
- Intake manifold
- Exhaust manifold
- Oil filler cap
- Intake and exhaust gaskets at head interfaces

Where a warrantable condition exists, Motorenfabrik Hatz will repair your engine at no cost to you including diagnosis, parts and labor.

## **MANUFACTURERS WARRANTY COVERAGE:**

The 2005 and later EPA certified nonroad compression ignition engines are warranted for 1500 hours of operation or two years of use, whichever first occurs.

If any emission related part on your engine is defective, the part will be repaired or replaced by Motorenfabrik Hatz.

## **OWNERS WARRANTY RESPONSIBILITIES:**

- As the engine owner, you are responsible for the performance of the required maintenance listed in your owner's manual. Motorenfabrik Hatz recommends that you retain all receipts covering maintenance on your engine, but Motorenfabrik Hatz cannot deny warranty solely for the lack of receipts or for your failure to ensure the performance of all scheduled maintenance.
- As the engine owner, you should be aware, however, that Motorenfabrik Hatz may deny you warranty coverage if your engine or a part has failed due to abuse, neglect, improper maintenance or unapproved modifications.
- You are responsible for presenting your engine to a Motorenfabrik Hatz authorized service center as soon as a problem exists. The warranty repairs should be completed in a reasonable amount of time, not to exceed 30 days.

If you have any questions regarding your warranty rights and responsibilities, you should contact HATZ DIESEL OF AMERICA, Inc. at (262) 544-0254.

## **HATZ DIESEL SUPPLEMENTAL WARRANTY FOR 2005 AND LATER EPA CERTIFIED ENGINES.**

## **PARTS WITH SUPPLEMENTAL LIMITED WARRANTY.**

The following limited warranty is supplemental to the standard HATZ DIESEL LIMITED ENGINE WARRANTY and covers 2005 and later EPA certified engines and applies to the following exhaust emission-related components:

- Fuel injection pump
- Injection nozzle
- Extra fuel device
- Crankcase breather valve assembly
- Air cleaner housing
- Intake manifold
- Exhaust manifold
- Oil filler cap
- Intake and exhaust gaskets at head interfaces

## **SUPPLEMENTAL LIMITED WARRANTY.**

Hatz Diesel of America, Inc. hereinafter referred to as “HATZ” warrants each of the above-listed parts when installed in a new engine sold by Hatz to be free from defects in material and workmanship under normal use and service, only under the named warranty coverage conditions, after the date of delivery to the original retail purchaser and Hatz will at their option, repair or replace at Hatz's sales headquarters, or at a point designated by Hatz, any part or parts which shall appear to the satisfaction of Hatz upon inspection at such point, to have been defective in material or workmanship.

- Any warranted part which is scheduled for replacement as required maintenance is warranted for the period of time up to the first scheduled replacement point for that part.
- Any replacement part which is equivalent in performance and durability may be used in non-warranty maintenance or repairs and will not reduce the overall engine warranty obligations of Hatz. However, Hatz is not responsible for failure of such replacement parts or failure of any other parts directly caused by failure of such replacement parts.
- This warranty does not obligate Hatz to bear any transportation charges in connection with the repair or replacement of defective parts. This warranty is transferrable to subsequent owners, only under the named warranty coverage conditions.
- In order to obtain service under this warranty, the retail purchaser should contact Hatz Diesel of America, Inc. at (262) 544-0254 for information and the nearest service center. The retail purchaser will not be charged for diagnostic labor which leads to the determination that a warranted part is defective, nor for the repair or replacement of warranted parts if the work is performed at an authorized Hatz service center. If other engine components are damaged due to a failure of the above-listed warranted parts still under warranty, these other engine components will also be repaired or replaced at no charge.
- This warranty shall not apply to any engine which shall have been installed or operated in a manner not recommended by Hatz, nor to any engine which shall have been repaired, altered, neglected, or used in any way which, in the opinion of Hatz, adversely affects its performance, nor to any engine in which parts not authorized by Hatz have been used, which parts or the use of which have damaged or caused defects in or otherwise adversely affected the engine or its performance, nor to normal maintenance service or replacement of normal service items.

Hatz reserves the right to modify, alter, and improve any engine or parts without incurring any obligation to replace any engine or parts previously sold with such modified, altered, or improved engine or parts.

**SUPPLEMENTAL INFORMATION  
TO THE OWNER'S MANUAL  
FOR 2005 AND LATER  
CALIFORNIA REGULATIONS FOR  
OFF-ROAD  
COMPRESSION-IGNITION ENGINES.**

## MAINTENANCE AND WARRANTY.

### **SUPPLEMENTAL INFORMATION TO THE OWNER'S MANUAL FOR 2005 AND LATER CALIFORNIA REGULATIONS FOR OFF-ROAD COMPRESSION-IGNITION ENGINES.**

The following supplemental information is furnished for California Off-Road Compression-Ignition Engines.

This information contains the following specific items:

- CARB-related engine parts and engine operating conditions
- Maintenance instructions for CARB-related engine parts
- Emission control system and adjustments
- Warranty statement

### **ENGINE PARTS AND / OR EQUIPMENT RELATED TO CARB EXHAUST EMISSION REGULATIONS.**

Parts which are mandatory for engine operation.

The following parts as manufactured according to HATZ specifications are mandatory for engine operation which meets CARB exhaust emission regulations.

- Fuel injector
- Fuel injection pump
- Cold start device
- Intake manifold
- Exhaust manifold
- Crankcase breather valve
- Oil filler Cap
- Intake and exhaust gaskets at head interfaces

Only parts manufactured by Hatz and which have passed the Hatz Quality Assurance Program are assured of meeting CARB exhaust emission regulations.

### **UNUSUAL OPERATING CONDITIONS.**

The engine must not be operated at a load factor less than 25 % for an extended period as such operation will cause the fuel injector to foul. If such a condition occurs, you should contact the nearest HATZ authorized Service Center for necessary repairs.

The engine is designed and adjusted to operate most efficiently at the following conditions:

- Air temperature of 25° C ( 77° F)
- Atmospheric pressure of 100 kPa (14.5 psi)
- Relative humidity of 30 %

Operation of the engine at conditions other than above will affect performance and exhaust emissions. Normally the equipment manufacturer takes this into account during the design of the machine and your equipment will perform within specifications over a wide range of climatic conditions. However if you must operate your equipment under very unusual climatic conditions, please contact your nearest Hatz distributor for advice.

### **MAINTENANCE SCHEDULE-CARB-RELATED PARTS.**

The following minimum intervals are being adopted for adjustment, cleaning, repair, or replacement of following components:

At 1,500 hours, and 1,500 hours intervals thereafter:

- Fuel injector tips (cleaning only)

At 3,000 hours, and 3000 hours intervals thereafter:

- Fuel Injectors

The exhaust quality of engines can be influenced by the execution (the quality of execution) of above described maintenance work.



Therefore, the maintenance work has to be carried out by a qualified workshop. Hatz authorised workshops, for example, are qualified workshops. Hatz Diesel of America will give you respective addresses, if required.

## **EMISSION CONTROL SYSTEM AND ADJUSTMENTS.**

The emission control system for this engine is EM (Engine Modification). No adjustments are needed or possible.

## **CALIFORNIA EMISSION CONTROL WARRANTY STATEMENT.**

### **YOUR WARRANTY RIGHTS AND OBLIGATIONS.**

The California Air Resources Board and Motorenfabrik Hatz GmbH & Co. KG are pleased to explain the emission control system warranty on your 2005 and later off-road compression-ignition engine. In California, new off-road compression-ignition engines must be designed, built, and equipped to meet the State's stringent anti-smog standards. Motorenfabrik Hatz GmbH & Co. KG must warrant the emission control system on your engine for the periods of time listed below provided there has been no abuse, neglect or improper maintenance of your engine.

Your emission control system may include parts such as the fuel-injection system and the air induction system. Also included may be hoses, belts, connectors and other emission-related assemblies.

Where a warrantable condition exists, Motorenfabrik Hatz will repair your off-road engine at no cost to you including diagnosis, parts and labor.

## **MANUFACTURER'S WARRANTY COVERAGE.**

The 2005 and later off-road compression-ignition engine is warranted for 1500 hours of operation or two years of use, whichever first occurs. If any emission-related part on your engine is defective, the part will be repaired or replaced by Motorenfabrik Hatz GmbH & Co. KG.

## **OWNER'S WARRANTY RESPONSIBILITIES.**

- As the off-road compression-ignition engine owner, you are responsible for the performance of the required maintenance listed in your owner's manual. Motorenfabrik Hatz GmbH & Co. KG recommends that you retain all receipts covering maintenance on your off-road compression-ignition engine, but Motorenfabrik Hatz GmbH & Co. KG cannot deny warranty solely for the lack of receipts or for your failure to ensure the performance of all scheduled maintenance.
- As the off-road compression-ignition engine owner, you should however be aware, that Motorenfabrik Hatz GmbH & Co. KG may deny you warranty coverage if your off-road compression-ignition engine or a part has failed due to abuse, neglect, improper maintenance or unapproved modifications.
- Your engine is designed to operate on diesel fuel only. Use of any other fuel may result in your engine no longer operating in compliance with California's emission requirements.
- You are responsible for initiating the warranty process. The ARB suggests that you present your off-road compression-ignition engine to a Motorenfabrik Hatz authorised dealer as soon as a problem exists. The warranty repairs should be completed by the dealer as expeditiously as possible.

If you have any questions regarding your warranty rights and responsibilities, you should contact HATZ DIESEL OF AMERICA, Inc. at (262)-544-0254.

**HATZ DIESEL SUPPLEMENTAL WARRANTY FOR 2005 AND LATER CALIFORNIA CERTIFIED OFF-ROAD COMPRESSION-IGNITION ENGINES.**

**PARTS WITH SUPPLEMENTAL LIMITED WARRANTY.**

The following limited warranty is supplemental to the standard HATZ DIESEL LIMITED ENGINE WARRANTY and covers 2005 and later California certified off-road compression-ignition engines and applies to the following exhaust emission-related components:

- Fuel injector
- Fuel injection pump
- Cold start device
- Intake manifold
- Exhaust manifold
- Crankcase breather valve
- Oil filler cap
- Intake and exhaust gaskets at head interfaces

## **SUPPLEMENTAL LIMITED WARRANTY.**

Hatz Diesel of America, Inc. hereinafter referred to as "HATZ" warrants each of the above-listed parts when installed in a new engine sold by Hatz to be free from defects in material and workmanship under normal use and service, for a period of twenty-four (24) months after the date of delivery to the original retail purchaser and Hatz will at their option, repair or replace at Hatz's sales headquarters, or at a point designated by Hatz, any part or parts which shall appear to the satisfaction of Hatz upon inspection at such point, to have been defective in material or workmanship.

- Any warranted part which is scheduled for replacement as required maintenance is warranted for the period of time up to the first scheduled replacement point for that part.
- Any replacement part which is equivalent in performance and durability may be used in non-warranty maintenance or repairs and will not reduce the overall engine warranty obligations of Hatz. However, Hatz is not responsible for failure of such replacement parts or failure of any other parts directly caused by failure of such replacement parts.
- This warranty does not obligate Hatz to bear any transportation charges in connection with the repair or replacement of defective parts. This warranty is transferrable to subsequent owners within the original twenty-four (24) months time period.
- In order to obtain service under this warranty, the retail purchaser should contact Hatz Diesel of America, Inc. at (262)-544-0254 for information and the nearest service center. The retail purchaser will not be charged for diagnostic labor which leads to the determination that a warranted part is defective, nor for the repair or replacement of warranted parts if the work is performed at an authorized Hatz service center. If other engine components are damaged due to a failure of the above-listed warranted parts still under warranty, these other engine components will also be repaired or replaced at no charge.
- This warranty shall not apply to any engine which shall have been installed or operated in a manner not recommended by Hatz, nor to any engine which shall have been repaired, altered, neglected, or used in any way which, in the opinion of Hatz, adversely affects its performance, nor to any engine in which parts not authorized by Hatz have been used, which parts or the use of which have damaged or caused defects in or otherwise adversely affected the engine or its performance, nor to normal maintenance service or replacement of normal service items.

Hatz reserves the right to modify, alter, and improve any engine or parts without incurring any obligation to replace any engine or parts previously sold with such modified, altered, or improved engine or parts.

CALIFORNIA

Proposition 65 Warning

Diesel engine exhaust and some of its constituents are known to the State of California to cause cancer, birth defects, and other reproductive harm.